



Technical Report

Title

Weathertightness testing of a sample of Matrix SFCM Rainscreen Cladding for PSP

Report Number & Date of Issue

N950/08/14067REV1
8 FEBRUARY, 2019

Author: D. Bennett	Position: Technician	TW Job No. 3JS3/C2707
Author's signature: 		
Checked by: S. R. Moxon		Position: Manager
Authorised by: S. R. Moxon		Position: Manager
Distribution (confidential)	- 1 copy to TW central area for archive - 1 copy to TW project file - 3 copies to PSP Architectural Limited	
Abstract		
<p>This report is copyright. Reproduction of the whole or any part thereof must not be made without the express permission of Taylor Woodrow. This report and the results shown and any recommendations or advice made herein are based upon the information, drawings, samples and tests referred to in the report. Where this report relates to a test for which Taylor Woodrow is UKAS accredited, opinions and interpretations expressed herein are outside the scope of UKAS accreditation. Taylor Woodrow accepts no liability for any damages, charges, costs (including, but not limited to, legal costs) or expenses in respect of or in relation to any damage to any property or other loss (save for death or personal injury occasioned by reason of any negligence on the part of Taylor Woodrow) whatsoever arising either directly or indirectly from the use of the report, the carrying out of any recommendations contained herein, the following of advice or the use of any goods or materials referred to in this report.</p>		

Taylor Woodrow Technology,
Technology Centre,
Stanbridge Road,
Leighton Buzzard,
Bedfordshire
LU7 4QH

Tel: +44 (0)1525 859111
Fax: +44 (0)1525 859112
technologycentre@uk.taylorwoodrow.com
www.taylorwoodrow.com/technologycentre



CONTENTS

1. INTRODUCTION.....3

2. DESCRIPTION OF TEST SAMPLE.....4

3. TEST RIG GENERAL ARRANGEMENT6

4. TEST SEQUENCE7

5. SUMMARY AND CLASSIFICATION OF TEST RESULTS8

6. WIND RESISTANCE TESTING.....9

7. WATERTIGHTNESS TESTING..... 15

8. IMPACT TESTING 18

9. APPENDIX – DRAWINGS.....22

1. INTRODUCTION

This report describes tests carried out at the Taylor Woodrow Technology Centre at the request of PSP Architectural Limited (PSP), Unit 11, All Saints Industrial Estate, Shildon County Durham, DL4 2RD.

The test sample consisted of a Matrix SFCM rainscreen cladding system.

Taylor Woodrow is accredited by the United Kingdom Accreditation Service as UKAS Testing Laboratory No.0057 and is also approved with Lloyds Register of Quality Assurance for ad-hoc in-service inspections and tests to ISO 9001 2000.

The tests were carried out on 12th May 2008 and were to determine the weathertightness of the test samples. The test methods were in accordance with the CWCT Standard Test Methods for building envelopes, 2005, for:

Wind resistance – serviceability & safety.

Watertightness – dynamic pressure & hose.

The sample was also subjected to the following non UKAS accredited tests in accordance with the Taylor Woodrow Quality System:

Impact resistance (BS 8200).

This test report relates only to the actual sample as tested and described herein.

The results are valid only for the conditions under which the tests were conducted.

The tests were witnessed wholly or in part by:

Gary Grosby	-	P.S.P.
John Burrell	-	P.S.P.
Ron Fitch	-	P.S.P.
Tamer Qaqish	-	P.S.P.
Neville Thompson	-	P.S.P.
Michael Hawkes	-	P.S.P.

2. DESCRIPTION OF TEST SAMPLE

2.1 GENERAL ARRANGEMENT

The sample is shown in the photo below and detailed in the drawing in the appendix.

The Matrix SFCM system used 4 mm thick ACM panels.

A plywood wall was located behind the rainscreen system. Viewing panels were incorporated in the wall to allow inspection during the dynamic water and hose tests.

PHOTO 4170029

TEST SAMPLE ELEVATION



2.2 CONTROLLED DISMANTLING

During the dismantling of the sample no discrepancies from the drawings were found.

PHOTO 6030005

MOUNTING FRAMEWORK FOF PANELS



3. TEST RIG GENERAL ARRANGEMENT

The test sample was mounted on a rigid test rig. The test rig comprised a well sealed chamber, fabricated from steel and plywood. A door was provided to allow access to the chamber. Representatives of PSP installed the sample on the test rig. See Figure 1.

FIGURE 1

TYPICAL TEST RIG GENERAL ARRANGEMENT

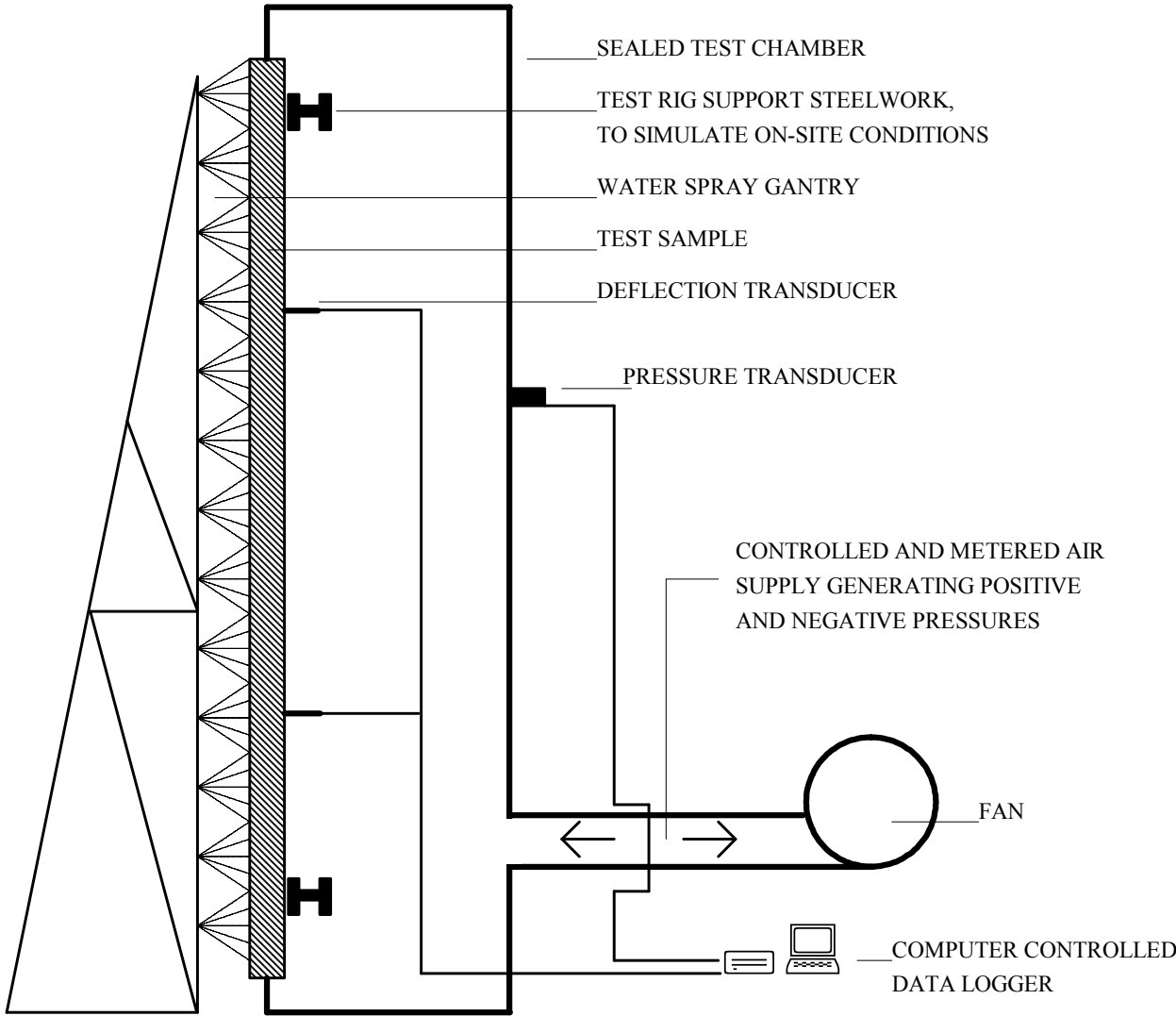

SECTION THROUGH TEST RIG

4. TEST SEQUENCE

The test sequence was as follows:

- (1) Wind resistance – serviceability
- (2) Watertightness – dynamic
- (3) Watertightness – hose
- (4) Wind resistance – safety
- (5) Impact resistance

5. SUMMARY AND CLASSIFICATION OF TEST RESULTS

The following summarises the results of the tests carried out. For full details refer to Sections 6, 7 and 8.

5.1 TEST RESULTS

TABLE 1

Date	Test number	Test description	Result
12 May 2008	1	Wind resistance – serviceability	Pass
12 May 2008	2	Water tightness – dynamic	Pass
12 May 2008	3	Watertightness – hose	Pass
12 May 2008	4	Wind resistance – safety	Pass
12 May 2008	5	Impact resistance	Pass

5.2 CLASSIFICATION

TABLE 2

Test	Standard	Classification / Declared value
Wind resistance	CWCT	2400 pascals

6. WIND RESISTANCE TESTING

6.1 INSTRUMENTATION

6.1.1 Pressure

One static pressure tapping was provided to measure the chamber pressure and was located so that the readings were unaffected by the velocity of the air supply into or out of the chamber.

A pressure transducer, capable of measuring rapid changes in pressure to within 2% was used to measure the differential pressure across the sample.

6.1.2 Deflection

Displacement transducers were used to measure the deflection of the tiles to an accuracy of 0.1 mm. The gauges were set normal to the sample framework at mid-span and as near to the supports of the tiles as possible and installed in such a way that the measurements were not influenced by the application of pressure or other loading to the sample. The gauges were located at the positions shown in Figure 2.

6.1.3 Temperature

Platinum resistance thermometers (PRT) were used to measure air temperatures to within 1°C.

6.1.4 General

During these tests the joints between the tiles were taped over.

Electronic instrument measurements were scanned by a computer controlled data logger, which also processed and stored the results.

All measuring instruments and relevant test equipment were calibrated and traceable to national standards.

6.2 FAN

The air supply system comprised a variable speed centrifugal fan and associated ducting and control valves to create positive and negative static pressure differentials. The fan provided essentially constant air flow at the fixed pressure for the period required by the tests and was capable of pressurising at a rate of approximately 600 pascals in one second.

6.3 PROCEDURE

6.3.1 Wind Resistance – serviceability

Three positive pressure differential pulses of 1200 pascals were applied to prepare the sample. The displacement transducers were then zeroed.

The sample was subjected to one positive pressure differential pulse from 0 to 2400 pascals to 0. The pressure was increased in four equal increments each maintained for 15 ±5 seconds. Displacement readings were taken at each increment. Residual deformations were measured on the pressure returning to zero.

Any damage or functional defects were recorded.

The test was then repeated using a negative pressure of -2400 pascals.

6.3.2 Wind Resistance – safety

Three positive pressure differential pulses of 1200 pascals were applied to prepare the sample. The displacement transducers were then zeroed.

The sample was subjected to one positive pressure differential pulse from 0 to 3600 pascals to 0. The pressure was increased as rapidly as possible but not in less than 1 second and maintained for 15 ± 5 seconds. Displacement readings were taken at peak pressure. Residual deformations were measured on the pressure returning to zero.

Any damage or functional defects were recorded.

The test was then repeated using a negative pressure of -3600 pascals.

FIGURE 2

DEFLECTION GAUGE LOCATIONS

External View

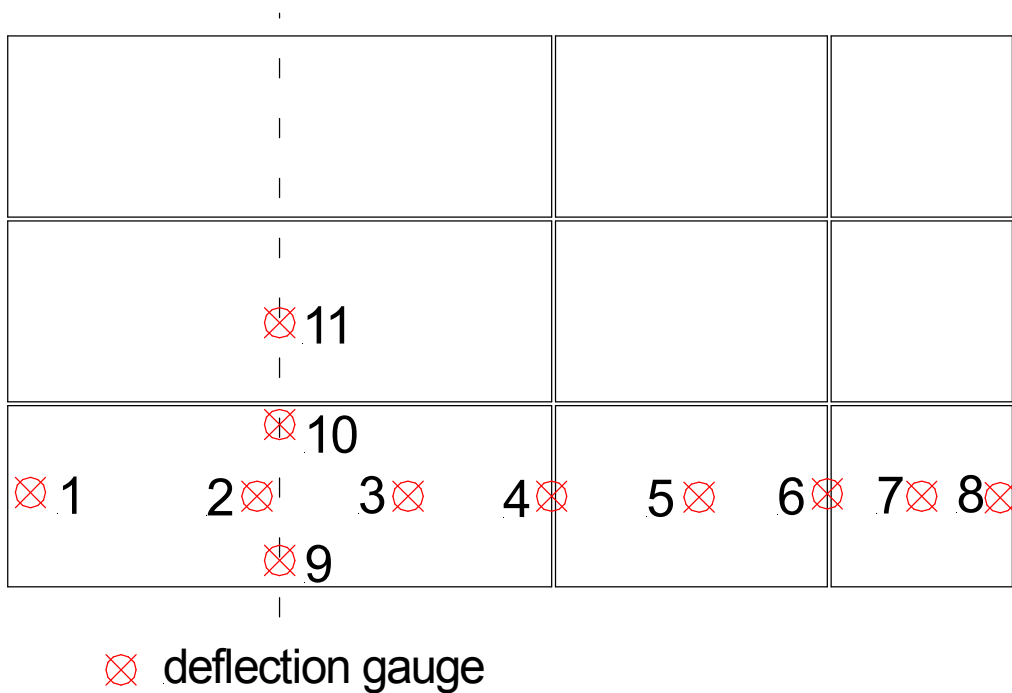

6.4 PASS/FAIL CRITERIA

6.4.1 Calculation of permissible deflection

Gauge number	Member	Span (L) (mm)	Permissible deflection (mm)	Permissible residual deformation
3	Back of panel	1800*	$L/90 = 20.0$	1 mm
5	Back of panel	1800*	$L/90 = 20.0$	1 mm
7	Back of panel	1200*	$L/90 = 13.3$	1 mm
10	Back of support rail	1250	$L/200 = 6.2$	1 mm

*diagonal span between supports

6.5 RESULTS

Test 1 (serviceability) Date: 12 May 2008

The deflections measured during the wind resistance test, at the positions shown in Figure 2, are shown in Tables 3 and 4.

Summary Table:

Gauge number	Member	Pressure differential (Pa)	Measured deflection (mm)	Residual deformation (mm)
3	Back of panel	2427	13.9	0.4
		-2397	-9.0	-0.2
5	Back of panel	2427	18.2	0.3
		-2397	-12.6	-0.4
7	Back of panel	2427	7.7	0.1
		-2397	-5.4	0.0
10	Back of vertical rail	2427	2.8	0.0
		-2397	-2.9	-0.1

No damage to the test sample was observed.

Ambient temperature = 19°C
Chamber temperature = 21°C

Test 4 (safety)

Date: 12 May 2008

The deflections measured during the structural safety test, at the positions shown in Figure 2, are shown in Table 5.

No damage to the sample was observed.

Ambient temperature = 19°C

Chamber temperature = 21°C

TABLE 3

WIND RESISTANCE – POSITIVE SERVICEABILITY TEST RESULTS

Position	Pressure (pascals) / Deflection (mm)				
	620	1239	1821	2427	Residual
1	1.3	3.2	5.1	6.9	0.1
2	2.0	4.5	7.3	10.2	0.3
3	5.5	11.5	17.4	23.2	0.6
4	2.0	4.1	6.4	8.5	0.2
5	6.2	13.0	19.3	25.2	0.3
6	1.2	2.6	4.2	5.6	-0.2
7	3.2	6.8	10.0	12.9	-0.1
8	0.8	2.1	3.6	4.7	-0.1
9	1.1	2.4	3.9	5.4	0.3
10	2.2	4.8	7.6	10.2	0.2
11	2.1	4.4	7.0	9.5	0.2
3 *	3.5	7.2	10.5	13.9	0.4
5 *	4.6	9.6	14.0	18.2	0.3
7 *	2.2	4.4	6.1	7.7	0.1
10 *	0.6	1.3	2.1	2.8	-0.1

* Mid-span reading adjusted between end support readings

TABLE 4

WIND RESISTANCE – NEGATIVE SERVICEABILITY TEST RESULTS

Position	Pressure (pascals) / Deflection (mm)				
	-636	-1193	-1816	-2397	Residual
1	-1.3	-2.4	-3.7	-5.1	0.0
2	-2.2	-4.4	-7.1	-10.0	-0.6
3	-5.2	-9.5	-14.3	-18.9	-0.7
4	-2.2	-4.3	-7.0	-9.7	-0.5
5	-5.8	-10.6	-15.8	-20.6	-0.6
6	-1.4	-2.9	-4.6	-6.2	0.0
7	-3.0	-5.7	-8.5	-10.9	0.0
8	-1.2	-2.4	-3.6	-4.7	0.1
9	-1.2	-2.4	-4.0	-5.7	-0.4
10	-2.4	-4.7	-7.8	-10.8	-0.7
11	-2.2	-4.4	-7.3	-10.3	-0.8
3 *	-3.0	-5.2	-7.2	-9.0	-0.2
5 *	-4.0	-7.0	-10.0	-12.6	-0.4
7 *	-1.7	-3.1	-4.4	-5.4	0.0
10 *	-0.7	-1.3	-2.2	-2.9	-0.1

* Mid-span reading adjusted between end support readings

TABLE 5

WIND RESISTANCE - SAFETY TEST RESULTS

Position	Pressure (pascals) / Deflection (mm)			
	3597	Residual	-3603	Residual
1	9.8	0.3	-7.7	-0.4
2	15.5	0.8	-15.5	-1.8
3	32.4	1.0	-26.9	-2.2
4	12.1	0.2	-14.2	-0.8
5	34.5	0.5	-28.0	-1.8
6	8.2	0.0	-8.7	-0.1
7	17.5	0.2	-14.4	-0.3
8	6.7	0.1	-5.8	-0.1
9	8.0	0.4	-8.8	-1.3
10	15.2	0.6	-15.6	-1.3
11	14.2	0.6	-14.6	-1.2
3 *	18.6	0.5	-12.1	-0.9
5 *	24.4	0.4	-16.5	-1.3
7 *	10.0	0.1	-7.1	-0.2
10 *	4.1	0.0	-3.8	-0.1

* Mid-span reading adjusted between end support readings

7. WATERTIGHTNESS TESTING

7.1 INSTRUMENTATION

7.1.1 Water Flow

An in-line water flow meter was used to measure water supplied to the spray gantry to within 5%.

7.1.2 Temperature

Platinum resistance thermometers (PRT) were used to measure air and water temperatures to within 1°C.

7.2 FAN

A wind generator was mounted adjacent to the external face of the sample and used to create positive pressure differentials during dynamic testing. The wind generator comprised a piston type aero-engine fitted with 4 m diameter contra-rotating propellers.

7.3 WATER SPRAY

7.3.1 Spray Gantry

The water spray system comprised nozzles spaced on a uniform grid not more than 700 mm apart and mounted approximately 400 mm from the face of the sample. The nozzles provided a full-cone pattern with a spray angle between 90° and 120°. The spray system delivered water uniformly against the exterior surface of the sample.

7.3.2 Hose test

The water was applied using a brass nozzle that produced a full-cone of water droplets with a nominal spray angle of 30°. The nozzle was used with a ¾" hose and provided with a control valve and a pressure gauge between the valve and nozzle.

7.4 PROCEDURE

7.4.1 Watertightness – dynamic

Water was sprayed onto the sample using the method described above at a flow rate of at least 3.4 litres/m²/minute.

The aero-engine was used to subject the sample to wind equivalent to a static pressure differential of 600 pascals. These conditions were maintained for 15 minutes. Throughout the test the inside of the sample was examined for water penetration.

7.4.2 Watertightness – hose

Working from the exterior, the selected area was wetted progressing from the lowest horizontal joint, then the intersecting vertical joints, then the next horizontal joint above, etc. The water was directed at the joint and perpendicular to the face of the sample. The nozzle was moved slowly back and forth above the joint at a distance of 0.3 metres from it for a period of 5 minutes for each 1.5 metres of joint. Shorter or slightly longer joints were tested pro rata. The water flow to the nozzle was adjusted to produce 22, ± 2 litres per minute when the water pressure at the nozzle inlet was 220, ± 20 kPa.

Throughout the test the interior face of the sample was examined for water penetration. The joints tested are shown in Figure 3.

FIGURE 3

HOSE TEST AREAS

External View

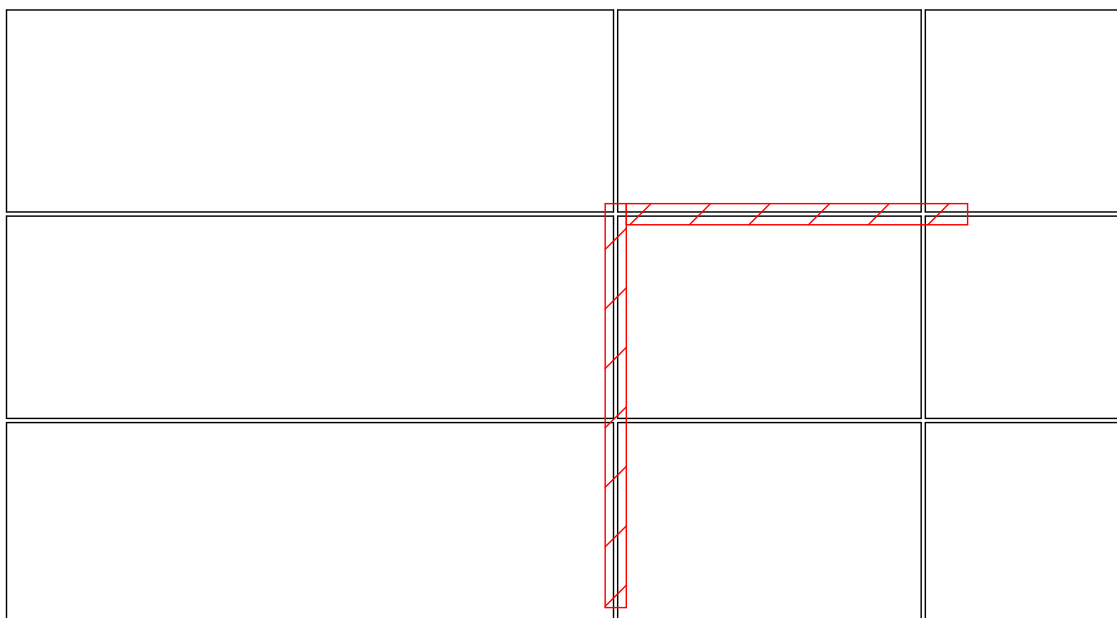

 hose test area

7.5 PASS/FAIL CRITERIA

There shall be no water leakage into the test chamber.

7.6 RESULTS

Test 2 (Dynamic pressure)

Date: 12 May 2008

Few drops of water observed on viewing ports but the mostly confined to back of rainscreen panels.

Chamber temperature= 21°C

Ambient temperature = 18°C

Water temperature = 16°C

Test 3 (Hose)

Date: 12 May 2008

Minor leakage contained to the back of rain screen.

Chamber temperature= 21°C

Ambient temperature = 18°C

Water temperature = 16°C

8. IMPACT TESTING

8.1 IMPACTOR

8.1.1 Soft body

The soft body impactor comprised a canvas spherical/conical bag 400 mm in diameter filled with 3 mm diameter glass spheres with a total mass of approximately 50 kg suspended from a cord at least 3 m long.

8.1.2 Hard body

The hard body impactor was a solid steel ball of 50 mm or 62.5 mm diameter and approximate mass of 0.5 kg or 1.0 kg.

8.2 PROCEDURE (BS 8200)

8.2.1 Soft body

The impactor almost touched the face of the sample when at rest. It was swung in a pendular movement to hit the sample normal to its face. The test was performed at locations 1, 2 and 3 shown in Figure 4. The impact energies were 120, 350 and 500 Nm.

8.2.2 Hard body

The impactor almost touched the face of the sample when at rest. It was swung in a pendular movement to hit the sample normal to its face. The test was performed at locations 4 and 5 shown in Figure 4. The impact energies were 3, 6 and 10 Nm.

8.3 PASS/FAIL CRITERIA

8.3.1 At impact energies for retention of performance

There shall be no failure, significant damage to surface finish or significant indentation.

8.3.2 At impact energies for safety

The structural safety of the building shall not be put at risk, no parts shall be made liable to fall or to cause serious injury to people inside or outside the building. The soft body impactor shall not pass through the wall. Damage to the finish and permanent deformation on the far side of the wall may occur.

8.4 RESULTS

Test 5 Impact resistance

Date: 12 May 2008

Location 1

120 Nm soft body. No damage to the sample was observed.

350 Nm soft body. No damage to the sample was observed.

500 Nm soft body. No damage to the sample was observed.

Location 2

120 Nm soft body. No damage to the sample was observed.

350 Nm soft body. Small indent in panel observed.

500 Nm soft body. Crease in top of panel, larger indent.

Location 3

120 Nm soft body. No damage to the sample was observed.

350 Nm soft body. Small indent in panel observed.

500 Nm soft body. Larger indent in panel. Top creased.

Location 4

3 Nm hard body. Small indent in panel observed.

6 Nm hard body. Small indent in panel observed.

10 Nm hard body. Small indent in panel observed.

Location 5

3 Nm hard body. Small indent in panel observed.

6 Nm hard body. Small indent in panel observed.

10 Nm hard body. Small indent in panel observed.

FIGURE 4

IMPACT TEST LOCATIONS

External View

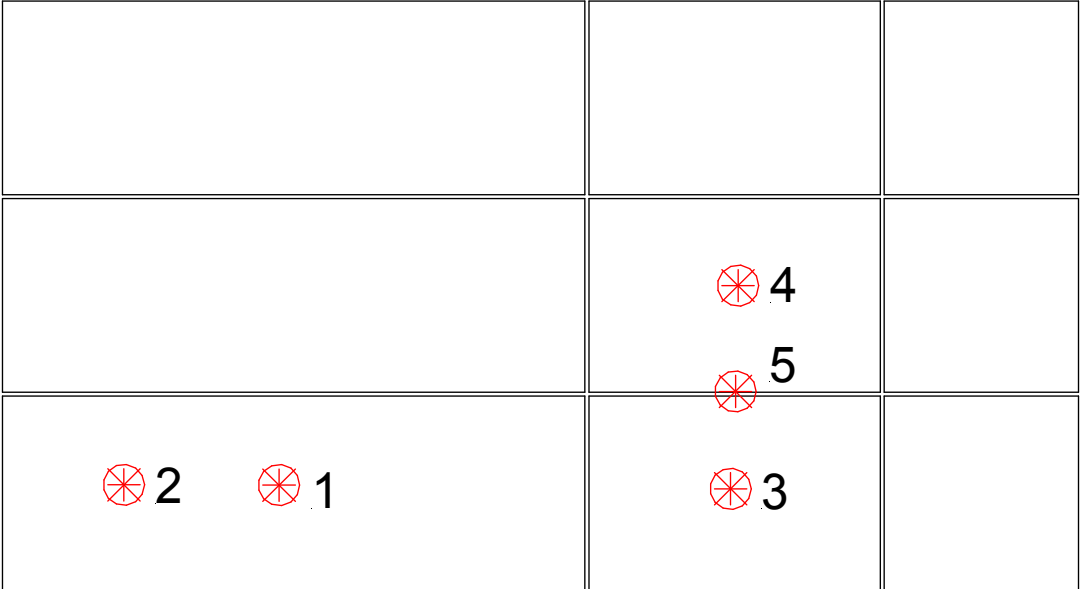

 impact location

PHOTO 5120070

PANEL AFTER IMPACT TEST



9. APPENDIX – DRAWINGS

The following unnumbered page is a copy of a PSP drawing of the test sample.

END OF REPORT

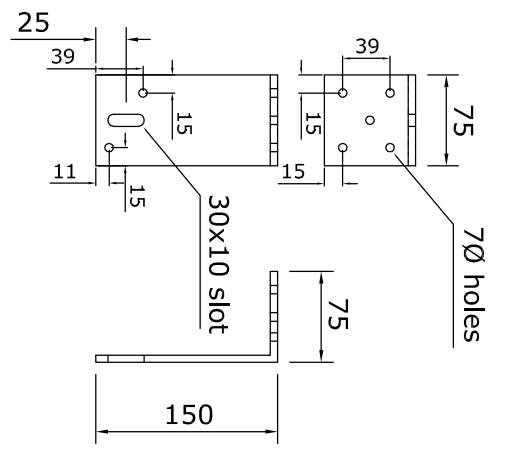
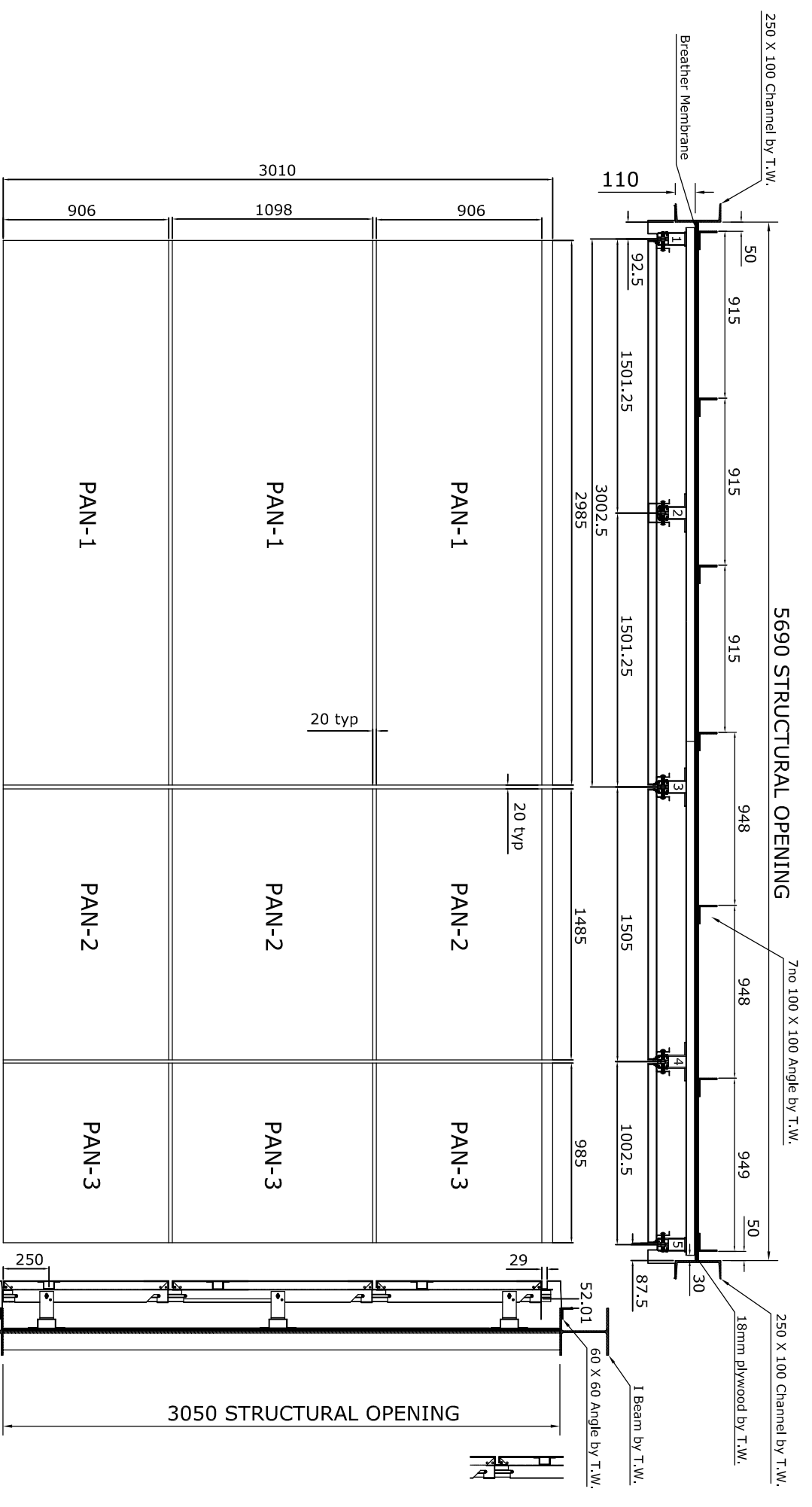

6MM ALI STRUCTURAL CLEAT
30no REQD

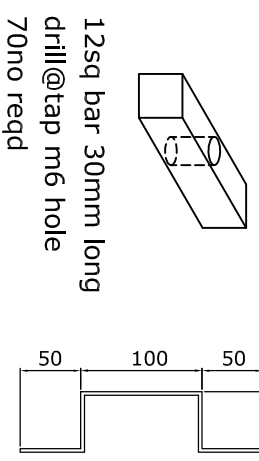

3MM GALV TOP HAT
3no @ 2815 LONG
1no @ 3000 LONG

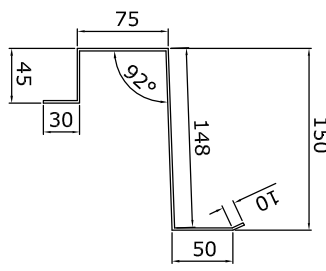

2MM ALI HEAD FLASH
2no @ 2353 LONG(1no with butt)
1no @ 3000 LONG(no butt)

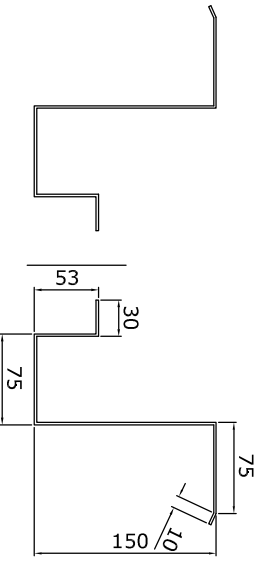

2MM ALI SIDE FLASH
2no @2058 LONG(no butts)
1no @3000 LONG(no butt)

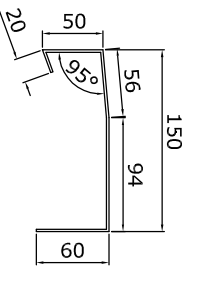

2MM ALI DRIP FLASH
2no @ 2353 LONG(1no with butt)
1no @ 3000 LONG(no butt)

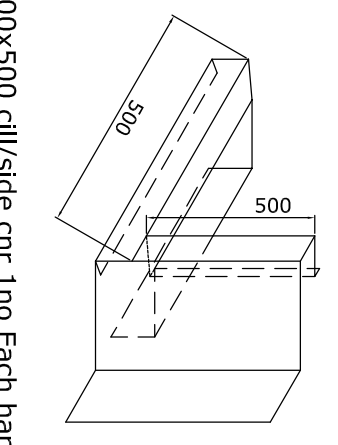

500x500 cill/side cnr 1no Each hand

corners welded not dressed
all aluminium mill finish
butts made from .9 ali

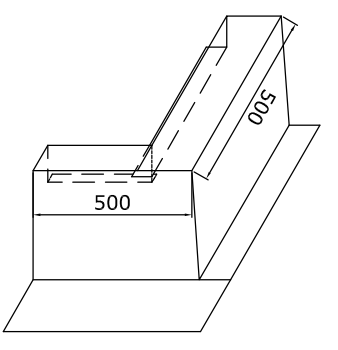

500x500 head/side cnr 1no Each hand

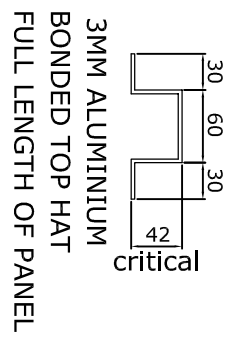
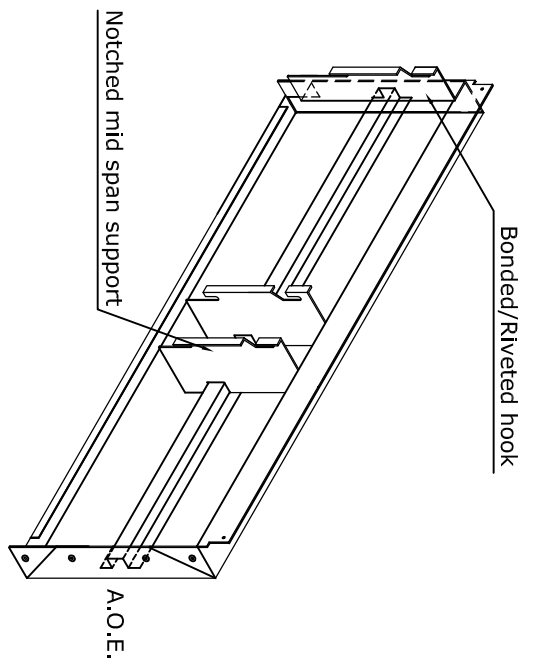

3MM ALUMINIUM
BONDED TOP HAT
FULL LENGTH OF PANEL

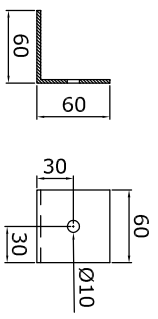

3MM GALV DRIP FIX ANGLE
10no @ 60 LONG

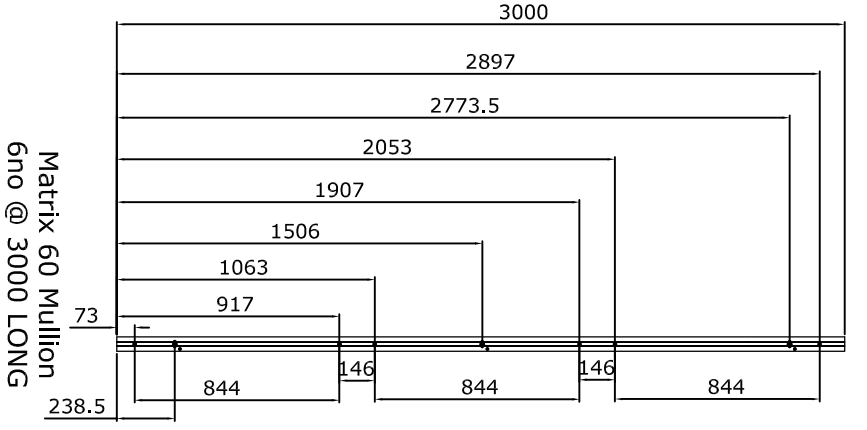

Revision	Date	Details
A	06-03-08	bottom field added to panel/1no galv top hat removed
B	26-03-08	mid span changed to I-sections/top hat introduced/
C	01-04-08	top keyhole moved down
D	22-04-08	15mm gap between panels changed to 20mm
E	23-04-08	hooks & midspan detail changed

Drawn by:- **M Hawkes** Checked by:-
Date:- **22/04/08** Scale:- **NTS**

Title:- **Matrix 3 CWCT Test**

Client:- **PSP**

Project:- **Taylor Woodrow Test Centre**

All Saints Industrial Estate
Shildon
Co. Durham
DL4 2RD

Tel:- 01388 770490
Fax:- 01388 778068
Email:- design@pspuuk.com
www.pspuk.com

Revision Dates	A	B	C	D	E
Original	05-02-08	06-03-08	26-03-08	01-04-08	22-04-08
Dwg. No.:-	Latest Revision:- E				